

JACE-603 MOUNTING AND WIRING GUIDE

The VYKON® JACE-603 is an embedded controller/server platform for integrated control and management of external devices over the Internet. Housed in a lockable metal enclosure, it includes a pre-wired transformer and a rechargeable 12V backup battery. The controller provides onboard I/O points along with communication ports for Ethernet, LonWorks® FTT-10, RS-485, and RS-232. Based on the NPM6E processor module, this JACE® controller runs the QNX real-time operating system and Oracle Hotspot Java VM, and supports either Niagara R2 or NiagaraAX 3.6 or higher, per the controller's installed license file. If running NiagaraAX, one installed JACE option card is supported, in addition to onboard SRAM for different backup configurations, including "battery-less".

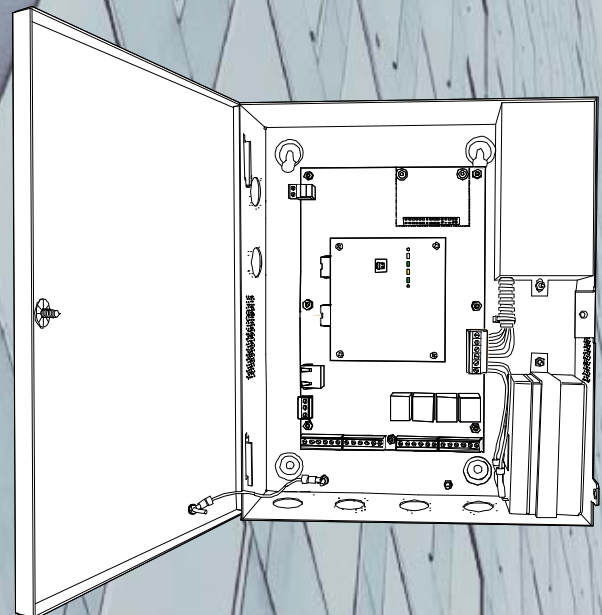

TABLE OF CONTENTS

About This Guide	3	Power Up and Initial Checkout ..	16
Related Documentation	3	Checking the Heartbeat LED	16
Preparation	3	About the Battery	16
Included in this Package	3	Commissioning Notes	17
Material and Tools Required	4	Controller LEDs	17
Precautions	4	LEDs on NPM6E processor module	17
Safety Precautions	4	Ethernet	17
Static Discharge Precautions	5	BEAT	17
WEEE (Waste of Electrical and Electronic Equipment)	5	STATUS	18
Mounting	5	LEDs on main circuit board	18
Removing and replacing the enclosure door	7	LON	18
Enclosure knockouts and mounting notes	7	Serial	18
Board Layout	8	Relay Output Status	18
Wiring Summary	9	Controller Jumpers	19
Power Wiring	9	Serial Shell mode	19
About the transformer	9	RS-485 port biasing	19
Making the power connection to the transformer	9	Need for RS-485 bias	19
Communications Wiring	10	Option Card Installation	
Ethernet	10	(NiagaraAX units only)	20
Serial	11	Maintaining the JACE-603	21
RS-485	11	Cleaning	21
RS-232	11	Required Battery Maintenance	21
LonWorks (LON)	12	Replacing the 12V battery	22
I/O Wiring	12	Battery-less option	23
Inputs	12	Replacement Parts	23
Thermistor	13	Non-replaceable Parts	23
Resistive	13	Standard Replacement Parts	24
0–10 Vdc	14	Field Replacement Units	24
4–20 mA	14	Replacing the JACE-603 circuit board	25
Binary Input	15	Returning a Defective Unit	26
Outputs	16	Certifications	27
		Underwriters Laboratories, Inc (UL) / Canadian Standards	
		Association (CSA)	27
		Federal Communications Commission (FCC)	27
		Industry Canada Interference-Causing Equipment Standard	
		(ICES)	27
		Declaration of RoHS Compliance	27



© 2013 Tridium, Inc.
3951 Westerre Parkway, Suite 350
Richmond, Virginia 23233 USA

Information and/or specifications published here are current as of the date of publication of this document. Tridium, Inc. reserves the right to change or modify specifications without prior notice. The latest product specifications can be found by contacting our corporate headquarters, Richmond, Virginia. Products or features contained herein are covered by one or more U.S. or foreign patents. This document may be copied by parties who are authorized to distribute Tridium products in connection with distribution of those products, subject to the contracts that authorize such distribution. It may not otherwise, in whole or in part, be copied, photocopied, reproduced, translated, or reduced to any electronic medium or machine-readable form without prior written consent from Tridium, Inc. Complete confidentiality, trademark, copyright and patent notifications can be found at: <http://www.tridium.com/galleries/SignUp/Confidentiality.pdf>

JACE, Niagara Framework, Niagara AX Framework and the Sedona Framework are trademarks of Tridium, Inc.

About This Guide

This document covers the mounting and wiring of the VYKON[®] JACE-603 (J-603) controller. It assumes that you are an engineer, technician, or service person who has performed control system installations. Instructions in this document apply to the following products:

Model	Description	I/O, Ports/Notes
J-603, J-603I	<p>JACE controller with onboard I/O points, mounted in metal enclosure. Has pre-wired power transformer and rechargeable 12V backup battery. (J-603 is for U.S. installations, J-603I is for International).</p> <p>Controller uses an NPM6E processor module with a PowerPC 440EP CPU, 256MB DDR RAM, 128MB Serial Flash, 512KB Boot Flash, 512KB Static RAM (SRAM), and runs the QNX Real-time Operating System and the Oracle Hotspot Java Virtual Machine.</p> <p>Can host either a Niagara R2 station (Niagara 2.301.535 or later) or a NiagaraAX station (NiagaraAX 3.6.45 or later), depending on license.</p> <p>Regardless of release, Niagara host (platform) configuration requires NiagaraAX Workbench 3.6.45 or later. If hosting an R2 station, the existing R2 Niagara Java Desktop Environment (JDE), build 2.301.535 or later, is used to access the controller's running station.</p>	<p>6 - Universal Inputs (UIs) for 10K ohm Type III thermistor sensors, 4-20mA or 0-10Vdc sensors, or dry contact closure.</p> <p>4 - Form C (SPDT) Relay Outputs for 24Vac/dc up to 2A resistive loads.</p> <p>2 - Ethernet 10/100 Mbit/s ports (RJ-485).</p> <p>1 - LonWorks FTT-10A port, 2-position.</p> <p>1 - RS-485 port, 3-position.</p> <p>1 - RS-232 (RJ-45 connector).</p> <p>All I/O connections and LON, RS-485 ports use pluggable screw terminal connectors.</p>

For complete specifications, please refer to the product data sheet for the JACE-603 controller.



Note Not covered in this document is the Niagara R2 or Niagara^{AX} software installation and configuration required for a fully functioning unit. See the “[Related Documentation](#)” section below.

Related Documentation

For software details on configuring and using the JACE-603 controller, consult the following documents:

- *Retrofit Board Niagara R2 Install & Startup Guide* (if Niagara R2)
- *JACE NiagaraAX Install and Startup Guide* (if NiagaraAX)
- *JACE Data Recovery Service (SRAM Support) - Engineering Notes* (if NiagaraAX)

Preparation

Unpack the controller and inspect the package contents for damaged or missing items. If damaged, notify the appropriate carrier and return for immediate repair or replacement.

- [Included in this Package](#)
- [Material and Tools Required](#)

Included in this Package

Included in this package you should find the following items:

- a JACE-603 controller, either model J-603 (U.S.) or J-603I (International).
- a hardware bag containing the following items:
 - 499 ohm resistors (quantity 6).
 - 6-position I/O screw terminal connector plugs (quantity 4).
 - 3-position RS-485 screw terminal connector plug (quantity 1).
 - 2-position LON screw terminal connector plug (quantity 1).
 - if a J-603, wire nuts (quantity 2).
- This *JACE-603 Mounting and Wiring Guide* document.

- Optional items (if ordered):
 - RJ-45 to DB-9 adapter (for the RS-232 port).
 - Silver satin patch cable (used between the adapter and serial port).

Material and Tools Required

The following supplies and tools are used for installation:

- 1/4" (6mm) nut driver: used to remove the transformer shield, and also the enclosure door grounding wire. If installing an option card (NiagaraAX units only), a #2 Phillips screwdriver.
- Small flat-blade screwdriver: used for I/O, LON, and RS-485 connectors. Also for power terminals if a J-603I (International) model.
- Suitable tools, fasteners, and supplies for mounting the controller's metal enclosure, and also for fastening electrical conduit.



Note If removing or installing the circuit board from the enclosure, a 1/4-inch thin-walled *socket* is recommended (*do not use a nut driver*). See [“Replacing the JACE-603 circuit board,”](#) page 25.

Precautions

This document uses the following warning and caution conventions:



Caution Cautions remind the reader to be careful. They alert readers to situations where there is a chance that the reader might perform an action that cannot be undone, might receive unexpected results, or might lose data. Cautions contain an explanation of why the action is potentially problematic.



Warning Warnings alert the reader to proceed with extreme care in situations where there is a chance that the reader might do something that can result in personal injury or equipment damage. Warnings contain an explanation of why the action is potentially dangerous.

Safety Precautions

The following items are warnings of a general nature relating to the installation and start-up of the controller. Be sure to heed these warnings to prevent personal injury or equipment damage.



-
- Warning**
- **A 120Vac circuit powers the transformer in the unit. Disconnect power before installation or servicing to prevent electrical shock or equipment damage.**
 - **Make all connections in accordance with national and local electrical codes. Use copper conductors only.**
 - **To reduce the risk of fire or electrical shock, install in a controlled environment relatively free of contaminants.**
 - **This device is only intended for use as a monitoring and control device. To prevent data loss or equipment damage, do not use it for any other purpose.**
-

Static Discharge Precautions

Static charges produce voltages high enough to damage electronic components. The JACE printed circuit board contains components that are sensitive to static discharge. Follow these precautions when installing or servicing the system:



Caution — Work in a static-free area.

- Discharge any static electricity you may have accumulated. Discharge static electricity by touching a known, securely grounded object.
- Do not handle printed circuit boards (PCBs) without proper protection against static discharge. Use a wrist strap when handling PCBs. The wrist strap clamp must be secured to earth ground.

WEEE (Waste of Electrical and Electronic Equipment)

Recycling of Electronic Products: (International Installations)

In 2006 the European Union adopted regulations (WEEE) for the collection and recycling of all waste electrical and electronic equipment. It is no longer allowable to simply throw away such equipment. Instead, these products must enter the recycling process. To properly dispose of this product, please take it to a local recycling center.

If a local recycling center cannot be found, please return it to one of these offices:

Tridium Europe Ltd
1, The Grainstore
Brooks Green Road
Coolham, West Sussex
RH13 8GR United Kingdom

Tridium AP Sales and Technical Service Center
2206F Building-B, Eagle Plaza
No. 26 Xiaoyun Road
Chaoyang District, Beijing
P. R. China (100125)

Tridium, Inc.
2256 Dabney Road, Suite C
Richmond, VA 23230

Mounting

Mount the controller in a location that allows clearance for wiring, servicing, and module removal. For mounting details refer to [Figure 1](#) on page 6 (a drill template is provided on the [last page](#) of this document).

Note the following **environmental conditions**:

- This equipment is intended for **indoor use** only, at maximum altitude to 2,000 meters (6,562 feet).
- This equipment is for use in a Pollution Degree 2 environment, in overvoltage Category II applications.
- Do not expose the unit to ambient conditions outside of the range of 0°C (32° F) to 50°C (122° F) and relative humidity outside the range 5% to 80% non-condensing.
- If the unit is mounted inside an enclosure, that enclosure should be designed to keep the unit within its required operating range considering a 20-watt dissipation by the controller. This is especially important if the unit is mounted inside an enclosure with other heat producing equipment.
- Minimum clearance from the wall on which the unit is mounted is 0.2-inches (provided by the dimpled mounting feet). Ensure this space is not compromised and that airflow is not blocked behind the unit.
- Do not mount the unit:
 - in an area where excessive moisture, corrosive fumes, or explosive vapors are present.
 - where vibration or shock is likely to occur.
 - in a location subject to electrical noise. This includes the proximity of large electrical contractors, electrical machinery, welding equipment, and spark igniters.
- The unit is designed to be wall mounted with the battery situated towards the bottom of the unit. For proper airflow at temperature extremes, do not mount the unit oriented in any other way.

Removing and replacing the enclosure door

The JACE-603's cover (door) is removable. A knurled-edge, slotted-head screw secures the door closed.



Note

For a more secure installation, use a padlock in the security tab that protrudes through the door.

Procedure 1 Remove or replace the enclosure door.

Removing the enclosure door allows more light inside the unit, and makes mounting and wiring easier.

Step 1 Loosen the cover screw and open the enclosure door about half way.

Step 2 If the grounding wire near the bottom is fastened to the screw post on the inside of the door, use a 1/4" (6mm) nut driver to unfasten it from the door.

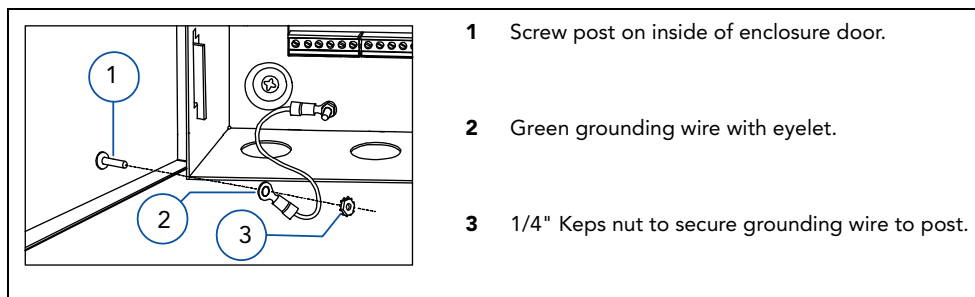

Set the nut aside to reuse later.

Step 3 Slide the door towards the top of the unit, until the hinge tabs on the door clear the hinge slots on the enclosure.

Step 4 Lift the door away from the unit.

When installation is finished, replace the door and grounding wire in the reverse fashion.

Enclosure knockouts and mounting notes

The JACE-603's enclosure has seven 1/2" (13mm) knockouts: one on top (for AC line power), two on the left side (typically used for comm cabling), and four on the bottom (typically used for I/O cabling). As needed, locate and remove the necessary knockouts and install the necessary conduit or cable clamps in the knockout holes. (This may easiest to do before mounting the controller to the wall).

Procedure 2 Mounting the controller.

Step 1 With the controller's enclosure door opened or removed, position the controller on the wall in the location where you are installing it.

Make sure that the location provides the necessary minimum clearances around the controller's enclosure (left and right sides, top and bottom). See [Figure 1](#) on page 6.

Step 2 Carefully mark the mounting hole locations, and remove the controller.

Step 3 Drill the needed pilot holes in the wall. For example, if using wall anchors you might drill 5/16" holes.

Step 4 Mount the controller to the wall using the appropriate fasteners.

Step 5 As needed, install wiring conduit to the controller's enclosure.

See "[Board Layout](#)," page 8 and "[Wiring Summary](#)," page 9 for further details.

Board Layout

Refer to [Figure 2](#) for location of I/O terminals, communication ports, LEDs, and other features of the JACE-603 controller.

Figure 2 JACE-603 board layout details

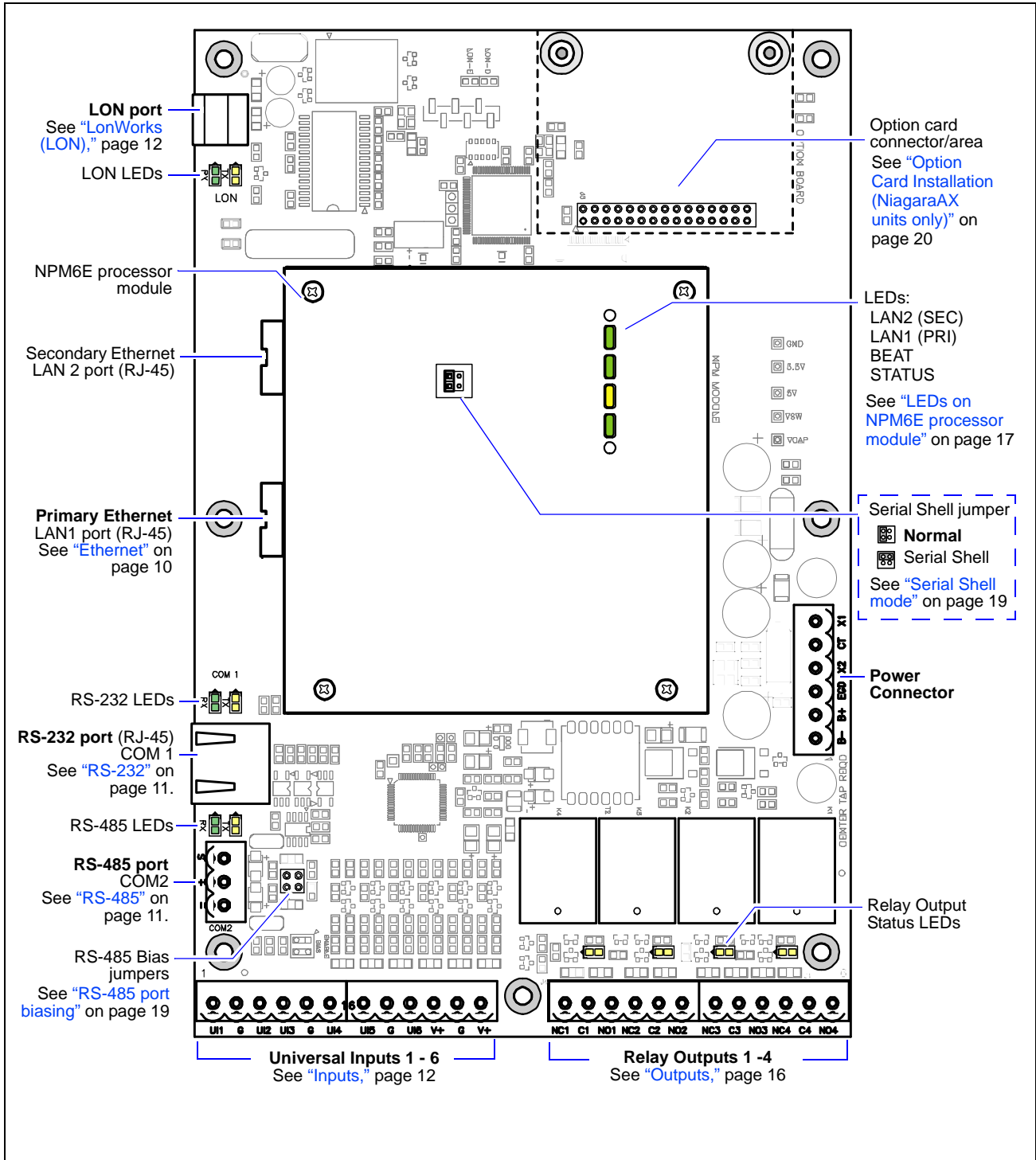

Wiring Summary

See [Figure 2](#) on page 8 to locate connectors and other components on the controller.

Make connections to the JACE in the following order.

- 1 With the 6-position power connector disconnected from the board, wire the power to the transformer (US models) or the power terminal block (International models). See [“Power Wiring,”](#) page 9.
- 2 Connect communications cables. See [“Communications Wiring,”](#) page 10.
- 3 Connect the I/O wiring. See [“I/O Wiring,”](#) page 12.
- 4 Apply power to the unit. See [“Power Up and Initial Checkout,”](#) page 16.

Power Wiring

Building power is wired directly to the transformer supplied with the controller. There is no disconnect switch in the unit, therefore you should wire the JACE to an external switch or breaker. Some local codes require the switch to be in sight of the unit. The switch must be capable of 120Vac (or if an International model, 240Vac), plus sufficient capacity for test equipment.

- [About the transformer](#)
- [Making the power connection to the transformer](#)

About the transformer

The J-603 (for U.S. installations) ships with a 120Vac, 50/60 Hz transformer.

The J-603I (for International) ships with a 240Vac, 50/60 Hz transformer.

The transformer provides power to the controller in a 14-CT-14 configuration (28Vac center tapped). The power connector has been disconnected for shipping.

The following things should be noted about the controller’s transformer:



-
- Warning**
- **Wiring is to be made to the supplied transformer. All connections should be made in accordance with national and local electrical codes.**
 - **Use 12-20 AWG power input wiring (3.31mm²–0.518mm²), copper conductors only.**
 - **Do not power other devices from the transformer of the JACE. The transformer should be dedicated to running the JACE controller.**
 - **Do not attempt to use any other power source or otherwise defeat the isolation provided by the integral transformer. A two-wire power source, including a 24V transformer, can cause permanent damage or greatly shorten the life of the unit.**
 - **Verify that neither side of the transformer's secondary winding is connected to earth ground or building neutral.**
-

Making the power connection to the transformer

With the 6-position power connector disconnected from the controller’s circuit board, unscrew the nut and locking washer and remove the metal divider (shield) over the transformer.



-
- Note**
- As typically required by code, high voltage “Class 1” wiring must be confined behind the transformer’s enclosure divider. Be sure to replace this barrier after completing the wiring. Do not pinch wires underneath the barrier when re-installing the barrier.
-

J-603

Using the provided wire nuts, connect 120Vac 60 Hz power to the transformer and power connector using the information in [Table 1](#).

Table 1 US models—building power termination.

Building Power Source (US)		Termination point
Type of Wire (12—20 AWG)	Typical Color of Wire	
Ungrounded—Hot	Black	Either wire of the 120V transformer
Grounded—Neutral	White	Other wire of the 120V transformer
Grounding—Ground (Earth)	Green or bare copper	Grounding stud

J-603I

Connect 240Vac 60 Hz power to the power terminal block using the information in [Table 2](#).

Table 2 International models—building power termination.

Building Power Source (International)		Termination point
Type of Wire (3.31mm ² —0.518mm ²)	Typical Color of Wire	
Ungrounded—Hot	Brown	Either empty terminus of the terminal block
Grounded—Neutral	Blue	Other empty terminus of the terminal block
Grounding—Protective Earth (Ground)	Green/yellow or bare copper	Grounding stud

Communications Wiring

All communications wiring is made through knockouts adjacent to the communication ports. Prior to connecting cables, ensure that the grommet bushing has been installed for each knockout. Employ strain relief on the communication wiring to prevent damage to the controller.

Ethernet

Two, female 10/100-Mbit Ethernet connections are provided on the controller’s NPM6E processor module. These RJ-45 connectors are labeled LAN1 (PRI) for primary and LAN2 (SEC) as secondary. Use a standard Ethernet patch cable for connecting to an Ethernet switch or hub.

The factory-default IP address for LAN1 is 192.168.1.12*n*, where the last numeral *n* matches the *last digit* in the controller’s *serial number*, and the subnet mask is 255.255.255.0. By default, LAN2 is disabled.



- Note** • Only LAN1 is supported if configuring the controller for *Niagara R2* (LAN2 is *not* supported).
- If configuring for *NiagaraAX*, LAN2 can be used in addition to LAN 1. Typically, you **only use LAN1** (primary port), unless you have a specific application for the other LAN2 port. For example, isolating a driver’s network traffic, using LAN2. Do **not** use LAN2 as the primary port. If enabling LAN2, note LAN1 and LAN2 must be connected to *different subnets*. Further, a JACE controller **does not provide IP routing or bridging** operation between the two LAN ports.

Refer to the “Install and Startup” documents in the [“Related Documentation”](#) on page 3 for further details on changing the controller’s TCP/IP configuration.

Serial

There are two serial ports on the JACE-603 controller (see [Figure 2](#) on page 8). The top serial port is an [RS-232](#) port using an RJ-45 connector. Below this is a two-wire with shield, non-isolated [RS-485](#) port.

RS-485

The controller's RS-485 port uses a 3-position connector, with screw terminals (from top-to-bottom) shield, plus (+), and minus (-). Use shielded, twisted-pair cabling wired in a continuous multidrop fashion to other RS-485 devices, meaning "minus to minus," "plus to plus," and "shield to shield." Connect the shield to earth ground at one end only, such as at the controller. Follow the field device manufacturers' recommendations regarding cable type, gauge, maximum number of devices and maximum cable lengths.

RS-232

One RS-232 serial port uses a female (socket) RJ-45 connector. Wire using an 8-conductor flat silver satin stranded cable with standard male (plug) RJ-45 connectors. Connect the flat satin cable (maximum distance 50 feet) through the enclosure knockout nearest the port. This "straight-through" cable is then connected to a socket-to-socket type RJ-45-to-DB-9 adapter.

The controller is a serial DTE device, such that another DTE device (for example, PC) requires a "null modem" adapter (part number 10148, optional item). If connecting the controller to a DCE device (for example, modem), use a straight-through adapter. [Table 3](#) provides pinouts for both adapter types.

Table 3 RJ-45 to DB-9 adapter pinouts.

RJ-45 and DB-9 Pinout References	Type of Adapter	RJ-45 Socket Pin	Signal		DB-9 Socket Pin
<p>RJ-45 Socket (female)</p> <p>DB-9 Socket (female)</p>	Null Modem (for connecting to another DTE device) Part number 10148	5	DCD	Data carrier detect	1
		3	TXD	Transmit data	2
		6	RXD	Receive data	3
		8	DSR	Data set ready	4
		4	GND	Ground	5
		1	DTR	Data terminal ready	6
		7	CTS	Clear to send	7
		2	RTS	Request to send	8
		—	not used on the JACE-4		9
	Straight-through (for connecting to a DCE device)	5	DCD	Data carrier detect	1
		6	RXD	Receive data	2
		3	TXD	Transmit data	3
		1	DTR	Data terminal ready	4
		4	GND	Ground	5
		8	DSR	Data set ready	6
		2	RTS	Request to send	7
		7	CTS	Clear to send	8
		—	not used on the JACE-4		9



-
- Note**
- Silver satin cable is not standard Ethernet UTP cable, in which the pairs are twisted around each other. The twisting of the pairs may cause undesirable effects on the serial communication, therefore we recommend the use of flat silver satin cable instead.
 - Flat silver satin cable is unshielded. If installing this cable in a noisy electrical environment, run the cable through conduit.
-

LonWorks (LON)

A single, two-pin, LonWorks FTT-10A Weidmuller connector is provided on the controller. This connection supports twisted pair, unshielded, polarity-insensitive, peer-to-peer communications at 78 Kbps.

Refer to the *LonWorks FTT-10A Free Topology Transceiver User's Guide* (078-0156-01F) for technical guidelines associated with free topology restrictions and the *Junction Box and Wiring Guidelines for Twisted Pair LonWorks Networks* (005-0023-01) for more detailed information on wiring specifications. These documents are available on Echelon's web site (www.echelon.com).

I/O Wiring

The JACE-603 provides six (6) universal **inputs** supporting analog inputs (temperature, resistance, voltage, and current) and digital inputs (contact closure, pulse count), as well as four (4) form-C (SPDT) relay **outputs**.

See [Figure 2](#) on page 8 for the location of these inputs and outputs.



-
- Note**
- For proper operation, each input or output used requires a special Niagara Direct Input/Output (Ndio) object to be properly configured in the station database. These objects act as the station interface to the physical I/O points. For details, please refer to the appropriate Niagara software configuration document:
- If Niagara^{AX}, the *NiagaraAX NDIO Guide*.
 - If Niagara r2.x, the *Niagara Standard Programming Reference*.
-

Inputs

Each of the 6 universal inputs can support any one of the following:

- **Thermistor** Type 3 (10K)
- **Resistive**
- **0–10 Vdc**
- **4–20 mA**
- **Binary Input**

Thermistor

The inputs support Type 3 10K Thermistor temperature sensors with a sensor range of -10° to 135°F (23.3° to 57.2°C), using the appropriate Niagara object. Input accuracy is in the range of ±1% of span.

Figure 3 shows the wiring diagram.

Figure 3 Thermistor wiring.

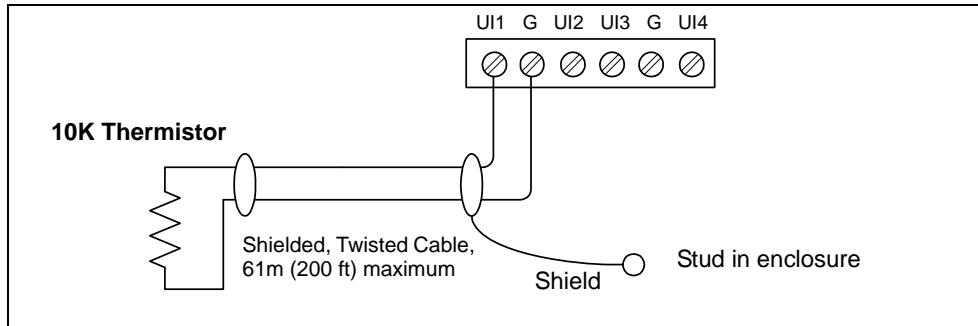

Note

UI inputs are optimized to provide the best resolution around the 10K ohm range. For a sensor with a range far from 10K ohms (such as a 100-ohm or 1000-ohm type), resolution will be poor. To use such a sensor, it is recommended you install a transmitter that produces a Vdc or mA signal, and then wire the transmitter to the UI according to the 0–10 Vdc or 4–20 mA instructions.

Resistive

Inputs support resistance inputs with a range of 0–100K ohms. Input accuracy is within ±1% of input span range. Figure 4 shows the wiring diagram.

Figure 4 Resistive wiring.

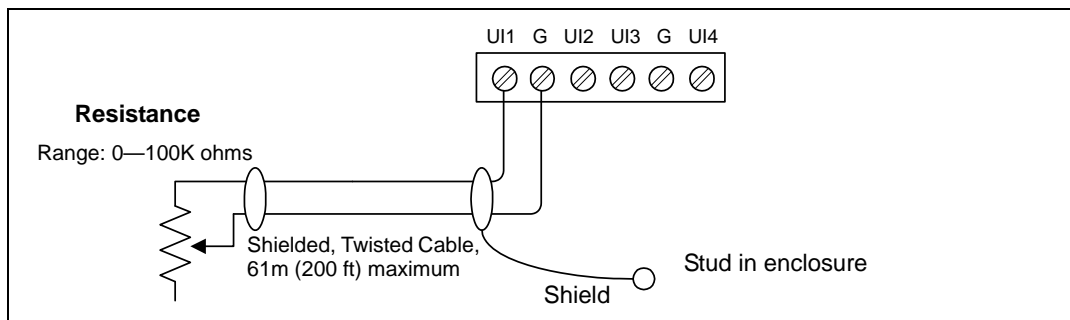

0–10 Vdc

Inputs support self-powered 0–10 Vdc sensors. Input impedance must be greater than 5K ohms. 0–10 volt accuracy is $\pm 2\%$ of span, without user calibration. [Figure 5](#) shows the wiring diagram.

Figure 5 0–10 Vdc wiring.

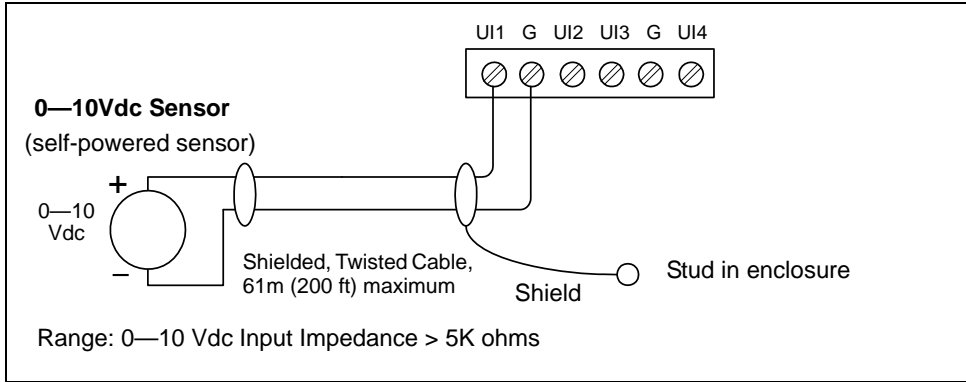

4–20 mA

Inputs support self-powered or controller-powered 4–20 mA sensors. For controller-powered sensors, the controller’s two V+ terminals supply 20 Vdc, at up to 80 mA combined. Input accuracy is $\pm 2\%$ of span, without user calibration.

The input requires an external 499-ohm resistor for current input (six are supplied with the unit).

[Figure 6](#) on page 14 shows wiring used for a self-powered sensor (top) and a 2-wire controller-powered sensor (bottom).

Figure 6 4 to 20 mA wiring.

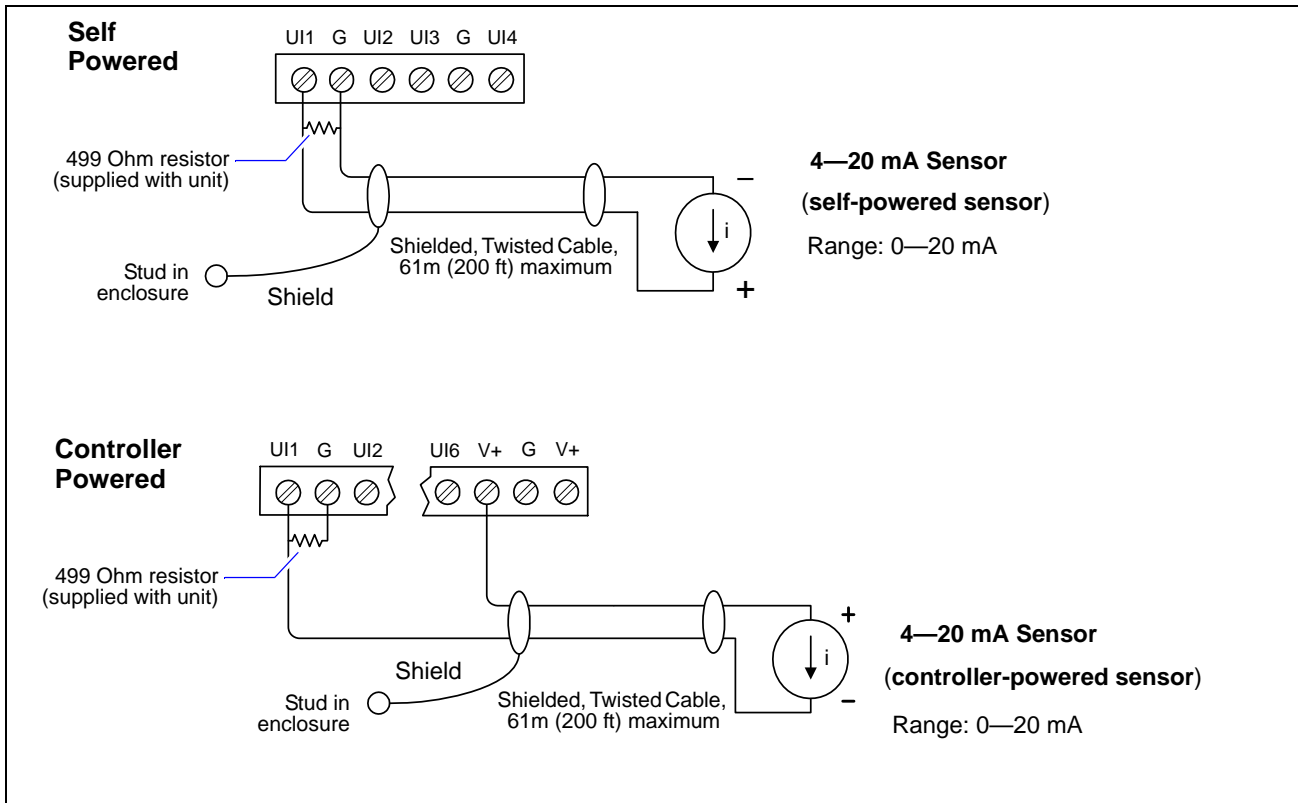

Binary Input

The inputs support both pulse contacts and normal dry (equipment status) contacts.

- Pulse contacts may have a change-of-state (COS) frequency of up to 20 Hz with a 50% duty cycle.
Note: Minimum dwell time must be > 25ms.
- Standard dry contacts must have a 1 Hz. (or less) COS frequency, with minimum dwell time > 500ms.

Both types of dry contacts support 3.3 Vdc open circuits or 330 μ A short-circuit current.

Figure 7 on page 15 shows the wiring diagram.

Figure 7 Binary input wiring.

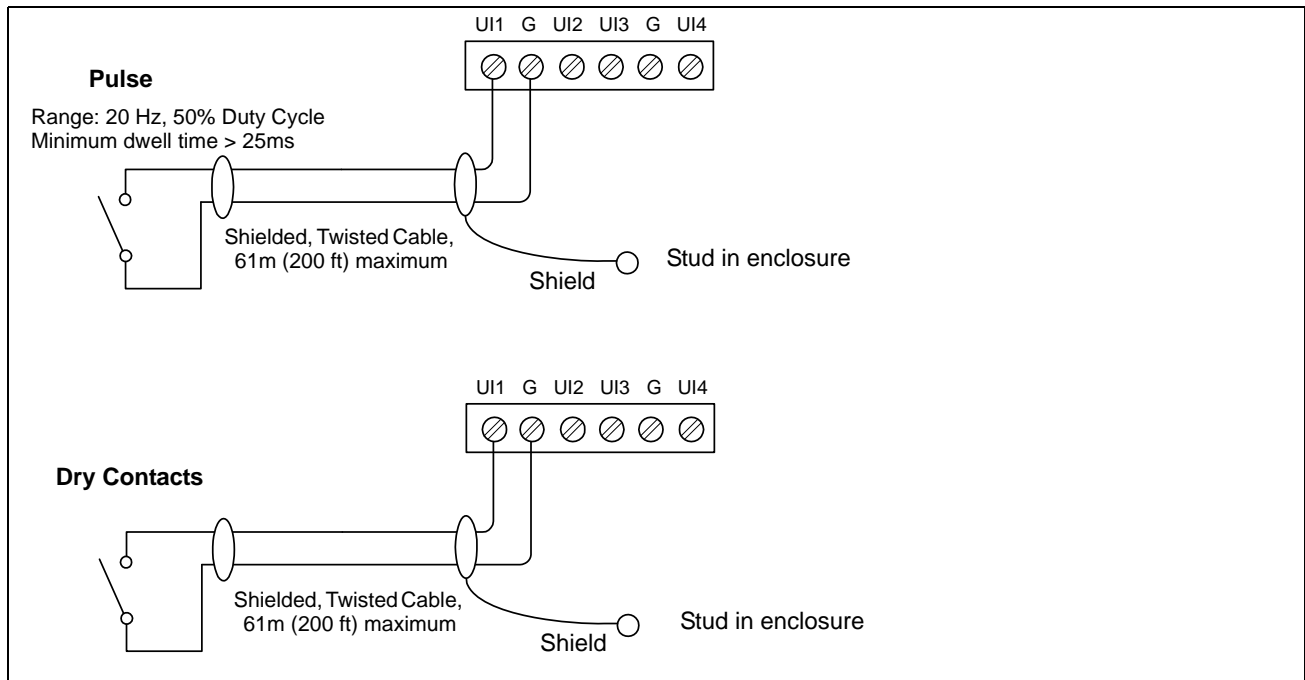

Outputs

Four (4) form-C relay outputs provide isolated dry-contact control of 24 VAC/DC loads at up to 2A resistive. An LED indicator for each relay is located between the relay and the wiring connection point (see the “Relay Output Status” section on page 18). [Figure 8](#) shows example wiring diagrams.

Figure 8 Example DO (relay) output wiring.

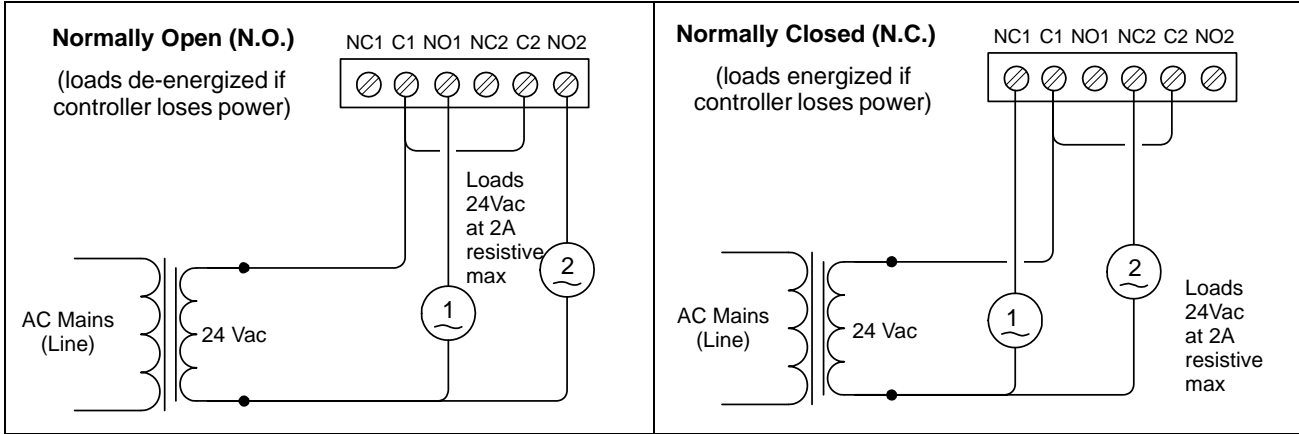

Power Up and Initial Checkout

Ensure power wiring to the transformer has been completed before proceeding (see the “Power Wiring” section on page 9). The JACE-603 controller does not include an on/off switch. To apply power, insert the 6-position power plug into the circuit board.

Refer to [Figure 2](#) on page 8 for the locations of the power connector and status LEDs on the controller.

Checking the Heartbeat LED

Verify the “STATUS” LED (on the NPM6E processor module) is lit green. This indicates that the system is OK and that power is applied.

Once the JACE boots, the adjacent yellow “BEAT” (heartbeat) LED begins blinking, with a typical rate of about 1 Hz. Blinking should begin within 30 seconds after power is applied.



Caution During the boot-up of a JACE-603 immediately following a *core software upgrade*, its heartbeat LED may blink in a 90% on — 10% off pattern. **Do not remove power during this period**, or data loss may result (I/O firmware upgrade may be in progress).

If after applying power, the STATUS LED goes out, or if the BEAT LED comes on (steady) and stays lit longer than 2 minutes, contact Systems Engineering for technical assistance. Also see “BEAT,” page 17.

About the Battery

The JACE-603 controller is provided with a sealed lead-acid 12V battery. If battery trouble messages are generated upon power up, contact Systems Engineering for technical support.



Note As shipped, the backup battery in a new JACE-603 controller *not* fully charged. Allow 24 hours of powered operation before relying on the battery to preserve station data on loss of power.

For more information on the use and replacement of the battery, refer to the “Required Battery Maintenance” section on page 21.

Commissioning Notes

To commission the JACE, open a Workbench AX-3.6.45 or later platform connection to the controller. You can do this using an Ethernet patch cable between your Workbench PC and the LAN1 (primary) port on the NPM6E processor module, where the factory default IP address for the LAN1 port is:

192.168.1.12 n where n is the last numeral of the controller's serial number
and the default subnet mask is 255.255.255.0

Then in the commissioning process, you reassign IP parameters as needed.

Or, first you can move a jumper on the NPM6E module to put the controller in “serial shell mode”. Then after rebooting it, you can communicate using an RS-232 connection between your PC and the RS-232 COM1 port on the controller's base board. This lets you use “system shell” to reassign its IP parameters **before** starting the commissioning process from Workbench. See “[Serial Shell mode](#)” on page 19.

See “[Related Documentation](#),” page 3, for documents that cover JACE Niagara installation and startup.

Controller LEDs

The JACE-603 controller provides a number of LEDs, including the following:

- [LEDs on NPM6E processor module](#) - Ethernet, Heartbeat, Status
- [LEDs on main circuit board](#) - LON, Serial, and Relay Output Status

LEDs on NPM6E processor module

Figure 9 shows the LEDs on the NPM6E processor module, with descriptions below.

Figure 9 LEDs on NPM6E processor module.

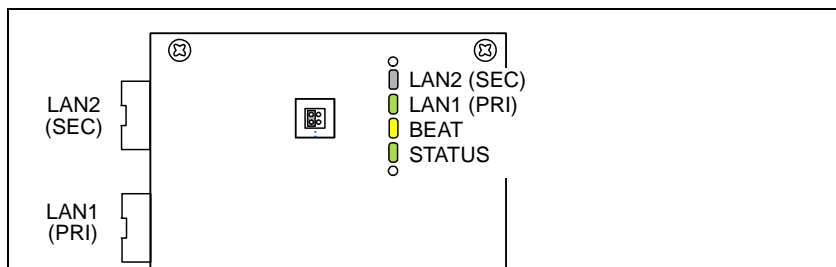

Ethernet

Each 10/100Mb Ethernet port, “LAN2” (Secondary) and “LAN1” (Primary) has one green LED on the NPM6E module. LED activity for an Ethernet port is as follows:

- Off—No Ethernet link is made.
- On—Ethernet link is present, but no activity on the LAN.
- Blinking—Ethernet link is present with data activity on the LAN.



Note The LAN2 (Secondary) Ethernet port is not supported in Niagara R2.

BEAT

(Heartbeat) In normal operation, the yellow “BEAT” LED should blink about once per second. If the heartbeat LED stays on constantly, does not light, or blinks very fast (more than once per second), contact System Engineering for technical support.



Caution During the boot-up of a JACE-603 immediately following a *core software upgrade*, its heartbeat LED may blink in a 90% on — 10% off pattern. **Do not remove power during this period**, or data loss may result (I/O firmware upgrade may be in progress).

STATUS

The “STATUS” LED provides a CPU machine status check, and should remain lit whenever the JACE is powered. If the STATUS LED does not light while power is applied, contact System Engineering for technical support.

LEDs on main circuit board

The JACE-603’s main circuit board has LEDs for [LON](#) and [Serial](#) ports, and [Relay Output Status](#) LEDs:

LON

Two LEDs are located near the LON port and show transmit and receive activity.

- The *yellow* transmit LED (TxD) indicates that the JACE is *transmitting* a message on the LON trunk.
- The *green* receive LED (RxD) indicates that another LonWorks device is transmitting a message.

Serial

Two LEDs for each RS-232 and RS-485 serial port are located near the ports on the main circuit board. They show transmit and receive activity for these serial ports.

- The *yellow* transmit LED indicates that the JACE is sending data out the serial port over a communications line to a connected device.
- The *green* receive LED indicates that the JACE is receiving data from a device.

These LEDs are driven by pulse detectors that provide a fixed on-time when data is detected on the port. If the receive LED is on constantly, this indicates a problem with the communications channel, such as a shorted wire or reversed wiring.

Relay Output Status

Four (4) relay output status LEDs are located below the associated form-C relay, just above the screw terminals for each output’s wiring. Under normal operation, these *yellow* LEDs indicate activity as follows:

- Off—Relay coil is not energized
- On—Relay coil is energized

Therefore, for a circuit with a normally open contact, an On status indicates that the contact is closed. For a circuit with a normally closed contact, an On status indicates that the contact is open.

Controller Jumpers

The controller has jumper blocks to allow for [Serial Shell mode](#) operation and for [RS-485 port biasing](#), as described below.

Serial Shell mode

The controller's NPM6E processor module has a four-pin jumper header and a 2-pin jumper block that you can reposition, as needed, to enable or disable "Serial Shell" mode operation. In this mode, the RS-232 COM1 port on the controller allows "system shell" menu access, using serial parameters: 115200, 8, N, 1.



Note You must *reboot* the controller *after repositioning this jumper* before any serial shell mode change becomes effective. When done using serial shell, don't forget to return to the jumper block to its normal position and reboot again.

The default jumper setting is "Normal" (no serial shell), see "[JACE-603 board layout details](#)" on page 8.

RS-485 port biasing

The controller has one RS-485 port (COM2) on the left side of the circuit board, near the bottom.

Figure 10 RS-485 bias jumpers on JACE-603.

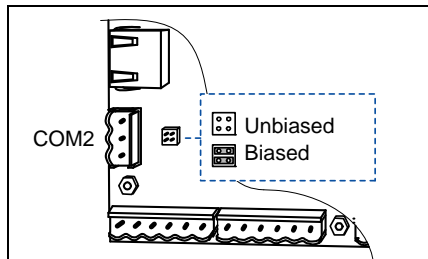

This RS-485 port has an adjacent four-pin jumper header, on which you can install *two* 2-pin jumper blocks to enable "RS-485 biasing", if needed. See [Figure 10](#) above.

As shipped from the factory, these pins are not shorted, thus the RS-485 port is *unbiased*. See "[Need for RS-485 bias](#)" for related background details.

Need for RS-485 bias



Note A full discussion of communications line termination is beyond the scope of this document.

Biasing sometimes improves RS-485 communications by eliminating "indeterminate" idle states. When you install two, 2-pin shorting blocks on an RS-485 port's bias jumper pins, this adds two onboard 3.3K ohm resistors into the controller's RS-485 circuit, as follows:

- from RS-485 "+" to 5V.
- from RS-485 "-" to Ground.



- Note**
- In general, only *one device* on an RS-485 trunk should be biased. Otherwise, undue circuit loading may result, with fewer devices supported.
 - RS-485 bias resistors are different than "termination resistors", externally installed at the two physical ends of a daisy-chained RS-485 trunk, across the "+" and "-" terminals. Termination resistors are typically 100 or 120 ohm value resistors.
 - Whenever termination resistors are used, RS-485 biasing is typically required.

Option Card Installation (NiagaraAX units only)

The JACE-603 circuit board provides one 30-pin option card slot, compatible with JACE 2/6 style option cards. Option card usage is supported only if the unit is configured with NiagaraAX (and *not* Niagara R2).



Warning Power to the controller must be OFF when installing or removing an option card, or damage will occur!

Also, you must be very careful to plug an option card into the connector properly (pins aligned).

Refer to the installation document that accompanies a specific option card for complete details.

Table 4 lists the different option card types, with notes specific to the JACE-603 controller.

Procedure 3 provides a basic set of installation steps.

Table 4 Option card types and NiagaraAX notes.

Option card model/type	JACE-603 Notes
NPB-232 (Single RS-232 port)	Uses COM3
NPB-2X-485 (Dual RS-485 ports)	Uses COM3 and COM4
NPB-LON (LonWorks FTT-10)	Operates as LON2
NPB-GPRS-W (Wireless GPRS modem)	Uses COM3 and COM4
NPB-SED-001 (Wireless Sedona Jennic option)	Uses COM3 (not available to station)
NPB-ZWAVE (Wireless Z-Wave serial gateway)	Uses COM3
NPB-SRAM (SRAM option)	Not Supported (controller has own SRAM)
NPB-MDM (Dialup modem)	Not Supported

Procedure 3 Installing an option card (NiagaraAX units only).

- Step 1 If applicable, backup the controller’s configuration to your PC using platform tools in NiagaraAX Workbench.
- Step 2 **Stop** any running station, using the Application Director platform view.
- Step 3 Unplug the 6-position power connector from the circuit board.
- Step 4 Using a #2 Phillips head screwdriver, remove the two screws from the option card mounting posts, and set them aside.
- Step 5 Carefully insert the pins of the option card into the option card socket. The mounting holes on the option card should line up with the standoffs on the base board. If they do not, the connector is not properly aligned. Press until the option card is completely seated.
- Step 6 Place the custom end plate that came with the option card over the connector(s) of the option card.
- Step 7 Replace the two screws through the end plate and into the standoffs on the controller’s base board. Using a screwdriver, hand tighten these screws.
- Step 8 Plug in the power connector in and verify operation.

Maintaining the JACE-603

This section provides information on the following topics:

- [Cleaning](#)
- [Required Battery Maintenance](#)
- [Replacement Parts](#)
- [Replacing the JACE-603 circuit board](#)
- [Returning a Defective Unit](#)

Cleaning

If dust or metal filings are present inside the unit, clean with vacuum or compressed air. Otherwise, no cleaning inside the unit is required. Optionally, if the outside of the metal enclosure becomes dirty, you can wipe it with a damp cloth and mild detergent.

Required Battery Maintenance

Typically, regular maintenance includes eventual replacement of the 12V sealed lead-acid backup battery (unless a NiagaraAX unit installed *without* the battery—see “[Battery-less option](#)” on page 23).

Battery life expectancy is a function of its discharge cycles (the number of discharges and their depth) and the ambient temperature of the battery during normal operation. In most applications, the battery should see relatively few discharges. Therefore, ambient temperature has more to do with determining the life expectancy of the battery than does any other factor.

If the controller is installed in a conditioned space, the battery should provide dependable service for approximately three years (average). In an environment where the operating temperature is higher (that is, 50°C or 122°F), you should only expect the battery to last approximately one year.

The battery is automatically float-charged during normal operation (while power is applied to the unit). The controller monitors the battery and periodically loads the battery to test its ability to maintain battery-backed functions. You should investigate any battery trouble message. Check the voltage level and its connections to the unit. Replace the battery as required.

To order a new battery, see the “[Standard Replacement Parts](#)” section on page 24.

Replacing the 12V battery

The battery is secured in the enclosure by a metal bracket and a nut (Figure 11).

Figure 11 12V sealed lead-acid battery in JACE-603 enclosure.

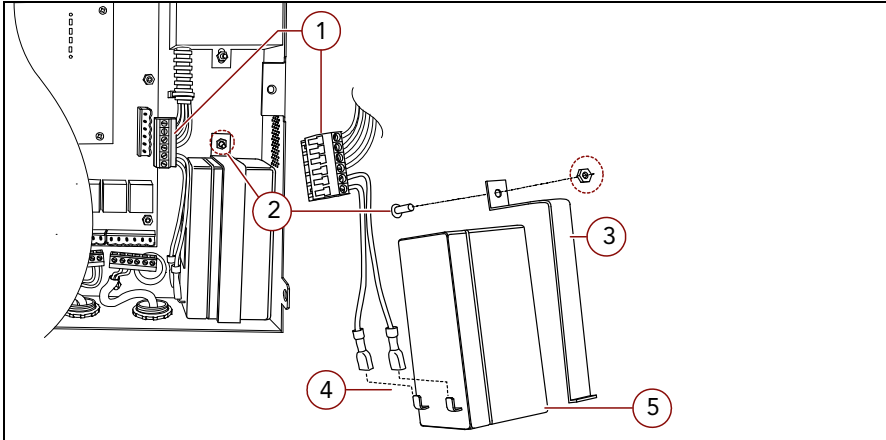

Item	Description
1	6-position power connector (unplug when replacing battery).
2	Enclosure mounting stud and Keps nut securing battery strap.
3	Metal battery bracket (bottom hooks into slot in enclosure bottom).
4	Quick-connect Faston battery terminals.
5	12V 1.2Ah sealed lead-acid battery, with 0.187" Faston quick-connect terminals.

Warning When replacing the battery or harness, maintain proper polarity as marked on the label inside the unit. Although the controller is fully protected against shorted battery terminals, the battery itself is not internally protected. Use extreme care to not short circuit the battery. A shorted battery may overheat rapidly and damage the power wiring harness or cause other physical harm to the hardware.

To replace the battery, follow the steps in Procedure 4.

Procedure 4 Replacing the 12V sealed lead-acid backup battery.

- Step 1 If applicable, backup the controller’s configuration to your PC using platform tools in NiagaraAX Workbench.
- Step 2 **Stop** any running station, using the Application Director platform view.
- Step 3 Unplug the 6-position power connector. Do not remove the male connector plug from the wiring harness.
- Step 4 Use a 1/4" (6mm) socket, unscrew the lock nut from the battery bracket.
- Step 5 Hold the battery in place while you remove the battery bracket.
- Step 6 Disconnect the two quick-connect terminals on the battery.

Note The controller will lose its time and date settings if it is disconnected from both battery and AC power for more than one hour.

Step 7 Remove the old battery and recycle as defined by your regional codes. For recycling within the US, see the labeling on the battery.

Step 8 Connect the quick-connect terminals to the new battery, ensuring that the:

- a RED (+) wire is connected to the positive battery terminal
- b BLACK (–) wire is connected to the negative battery terminal.

Step 9 Secure the new battery to the bottom of the unit with the bracket and tighten the lock nut.

Step 10 Plug in the power connector in and verify normal operation.

Battery-less option

A unit running NiagaraAX (*not* Niagara R2) can be software configured to operate “battery-less”, using only the onboard SRAM of the NPM6E processor module to maintain data in a power loss or brownout event. Or, the unit can be configured to use *both* its sealed lead-acid backup battery and SRAM backup.



Note

Although a JACE-603 (running NiagaraAX) *can* be configured to run without its provided backup battery, in most cases it is expected for the *battery to be used*. This provides immunity to “power quality events” including momentary power outages or brownouts—which otherwise can result in a controller *reboot*—even if for only one or two AC cycles (1/60th or 1/30th of a second). For a number of reasons, *other* models of SRAM-equipped controllers running NiagaraAX *may* be better candidates for a “battery-less” installation. Typically such controllers use a smaller, more difficult-to-replace NiMH (nickel metal hydride) battery pack, and are often mounted in areas harder to access than a JACE-603 controller. Refer to the documents listed in the [“Related Documentation”](#) on page 3 for configuration details on SRAM support.

Replacement Parts

Servicing the JACE-603 controller may call for replacement parts. There are three categories of parts:

- [Non-replaceable Parts](#)
- [Standard Replacement Parts](#)
- [Field Replacement Units](#)

Non-replaceable Parts

Other than the parts listed in the replacement parts sections, there are no serviceable components on the base assembly.

Memory

Any addition, modification, or replacement of memory components requires software configuration and is not a field upgrade. For additional information, consult your regional Tridium office.

Fuses

The controller contains a non-user replaceable fuse, soldered on the circuit board, and is not user-serviceable. If this circuitry is suspect, contact your regional Tridium office for technical support. See the [“Returning a Defective Unit”](#) section on page 26.

Standard Replacement Parts

Standard replacement parts are listed in [Table 5](#) and can be ordered from stock without restriction. Standard replacement parts cannot be returned for credit and should be disposed of in an appropriate manner.

Table 5 Standard replacement parts.

Part Number	Description
10023	Battery, 12 Vdc, 1.2 AH (see “Replacing the 12V battery,” page 22.)
10026	LON (LonWorks) Trunk Connector Plug, 2-position
10140	RS-485 connector plug, 3-position
10139	I/O connector plug, 6-position
10149	Resistor, 499 ohm, 1%, 0.6w
10138	Battery/ground harness (also includes 6-position power connector)
10148	Adapter, RJ-45 to DB-9 null modem, for serial port to connect to DTE device
10180	Silver satin patch cable, 4 feet (used between adapter and serial port)
10181	Silver satin patch cable, 10 feet (used between adapter and serial port)
10182	Silver satin patch cable, 25 feet (used between adapter and serial port)

Field Replacement Units

To replace a faulty unit, order from the field replacement units (FRUs) listed in [Table 6](#). An FRU consists of only the JACE-603 **circuit board**, without connector plugs.

FRU parts can be ordered from stock, but the replaced circuit board (removed from the JACE-603) must be returned to your vendor for credit.



- Note**
- Before ordering an FRU, it is strongly recommended that you contact your normal technical support resource to eliminate the possibility of a software issue or mis-configuration problem.
 - Be sure to contact Tridium for a return material authorization (RMA) number (see [“Returning a Defective Unit,”](#) page 26) before shipping an item for return credit or repair. To allow proper licensing of the replacement unit, please have information ready about the existing unit, including its serial number, model number, and license information, when placing the order.

Table 6 Field replacement units for JACE-603.

Part Number	Description
RB-603	Circuit board, J-603 or J-603I, Niagara AX (configurable also for Niagara R2).

Replacing the JACE-603 circuit board



- Caution** Be aware of small surface-mounted components on the circuit board near each mounting point!
- Use a 1/4" (6mm) thin-walled socket, not a nut driver, to carefully loosen or tighten the nuts that secure the JACE-603 circuit board to the 7 mounting studs. A nut driver can cause board damage to adjacent components, while a socket (if used carefully) typically does not.
 - Retain and reuse metal spacers on all mounting studs (between the board's back and enclosure).
 - Before handling circuit boards, discharge any accumulated static by touching the metal surface of the controller. For details, see "[Static Discharge Precautions](#)," page 5.

To replace the JACE-603 circuit board with an FRU circuit board in the field, follow [Procedure 5](#).

Procedure 5 Replacing an FRU circuit board.

- Step 1 Using the appropriate Niagara software tool, back up the station database to your PC.
- Step 2 Open the cover of the unit.
- Step 3 If any of your I/O points have voltage, turn the devices off or disconnect power to them.
- Step 4 Turn off building power to the unit. The unit should power down automatically.
- Step 5 Unplug the 6-position power connector from the board.
- Step 6 Note positions of all communications and I/O connectors going to the circuit board.
If necessary, label connectors to avoid mis-connection later (after circuit board is replaced).



Note The software that runs on the controller expects the terminal positions to be the same to collect data from or to control the attached devices.

- Step 7 Unplug all Ethernet, serial, LON, modem, and I/O connectors from the circuit board.
- Step 8 Using a 1/4" socket (see previous [Caution](#)), carefully remove and retain the seven 1/4" nuts securing the circuit board. Be mindful of small surface-mount components located near board mounting points.
- Step 9 Remove the circuit board.
Make sure that metal spacers (behind the board) remain on the seven mounting studs.
- Step 10 Replace the FRU circuit board on the mounting studs and spacers, carefully securing with the seven 1/4" nuts. Again, be mindful of small surface-mount components located near board mounting points.
- Step 11 Reconnect any Ethernet, serial, LON, and modem connectors.
- Step 12 Reconnect all I/O connectors.
- Step 13 Turn on building power to the unit.
- Step 14 Plug the 6-position power connector in and verify normal operation.
- Step 15 If any of your I/O points have voltage, turn the devices back on, or reconnect power to them.
- Step 16 Using NiagaraAX Workbench to make a platform connection, re-commission the JACE-603, including the following:
 - a Install the correct Niagara release and set the date and time.
 - b Install the new license file.
 - c Restore the station database and start the station.

Returning a Defective Unit

For proper credit on an in-warranty unit, ship the replaced circuit board to Tridium within 30 days.

Prior to returning the unit, contact one of the following Tridium offices to obtain a return materials authorization (RMA) number and other instructions.

Please provide:

- Product model
- Serial number
- Nature of the defect
- PO number to secure the RMA

United States

Phone: 804-254-7086, ext. 11

Email for RMA: rma@tridium.com

Return to:

Tridium, Inc.
2256 Dabney Road, Suite C
Richmond, VA 23230
Attn: Return Department RMA# _____

Europe

Phone: +44 (0) 1403 740290

Fax: +44 (0) 1403 741804

Email for technical support: supportuk@tridium.com

Email for product orders: ordersuk@tridium.com

Return to:

Tridium Europe Ltd
1, The Grainstore
Brooks Green Road
Coolham, West Sussex
RH13 8GR United Kingdom
Attn: Return Department RMA# _____

Asia/Pacific

Phone: +65 6887 5154

Fax: +65 6887 5342

Email for technical support: hclim@tridium.com

Return to:

Tridium Asia Pacific Pte Ltd
17 Changi Business Park Central 1
Honeywell Building
Attn: Mr Lim Hoon Chat, Engineering Mgr.
Singapore 486073
Attn: Return Department RA# _____

Australia/Asia Pacific Sales:

Phone: +61 4 1264 4234

Email: mhodder@tridium.com

Certifications

The JACE-603 (J-603, J-603I) has the following agency listings, compliances, and certifications:

- UL 916 Standard For Energy Management Equipment
- CSA C22.2 No. 205 Signal Equipment
- FCC Part 15, Class B - Federal Communications Commission
- ICES-003, Class B - Industry Canada Interference-Causing Equipment Standard
- EU 202/95/EC RoHS (Restriction of Hazardous Substances)

For complete details on the listings and compliances for these controllers, refer to the document *Agency Listings and Approvals for Tridium Hardware Products*.

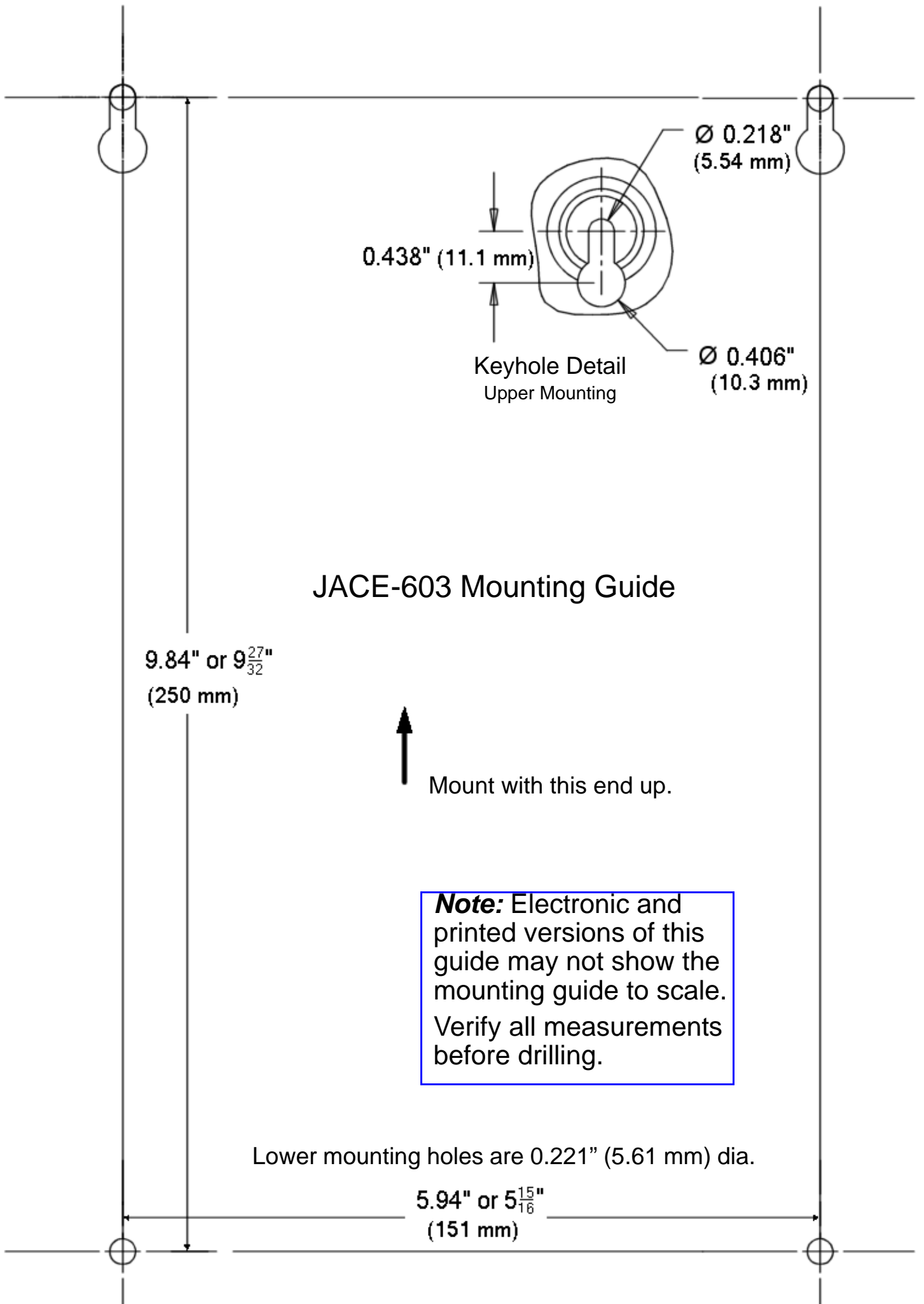

Ø 0.218"
(5.54 mm)

0.438" (11.1 mm)

Keyhole Detail
Upper Mounting

Ø 0.406"
(10.3 mm)

JACE-603 Mounting Guide

9.84" or $9\frac{27}{32}$ "
(250 mm)



Mount with this end up.

Note: Electronic and printed versions of this guide may not show the mounting guide to scale. Verify all measurements before drilling.

Lower mounting holes are 0.221" (5.61 mm) dia.

5.94" or $5\frac{15}{16}$ "
(151 mm)