

iSMA-B-FCU-LL

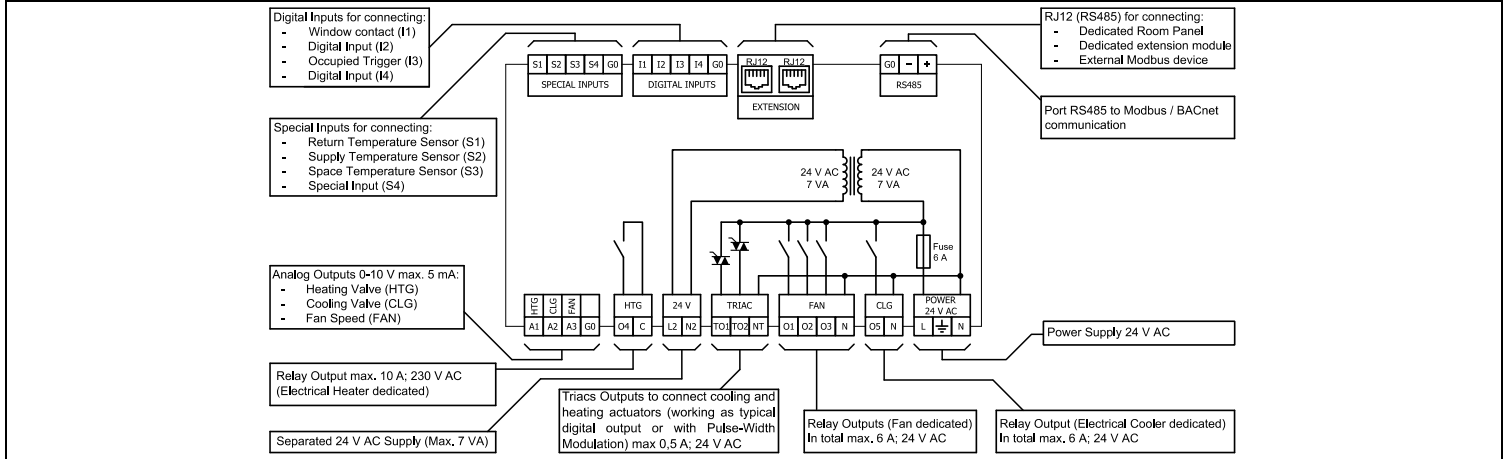

SPECIFICATION	
Power supply	24 V AC, 6 A built-in fuse, max. 22 VA
Special inputs	Resistance, temperature and voltage 0-10 V
Digital Inputs	Dry contact
Analog outputs	3x 0-10 V DC, max. 5 mA
Triac outputs	2x 24 V AC, 0,5 A
Digital outputs	4x 24 V AC 6 A (in total), HTG 230 V AC 10 A
Interface	RS485, up to 128 devices on the bus
Ingress protection	IP20 - for indoor installation
Temperature	Operating -10°C - +50°C; Storage - 40°C - +85°C
Relative humidity	5 to 95% RH (without condensation)
Connectors	2.5 mm ²
Mounting	DIN rail mounting
Dimensions	123,5 x 137 x 55 mm
Housing material	Plastic, self-extinguishing PC/ABS

BLOCK DIAGRAM



FAN CONNECTION

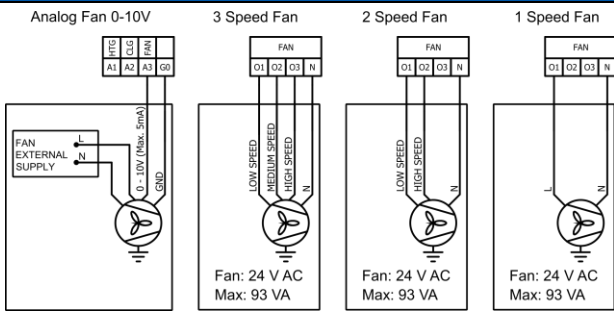

THERMAL VALVES

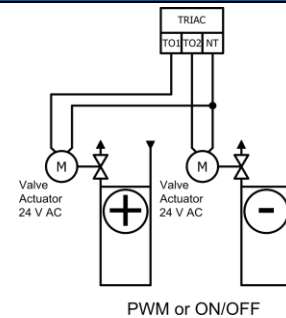

ANALOG VALVES

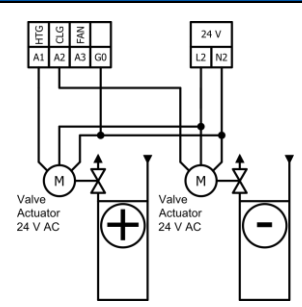

ELECTRICAL HEATER AND COOLER

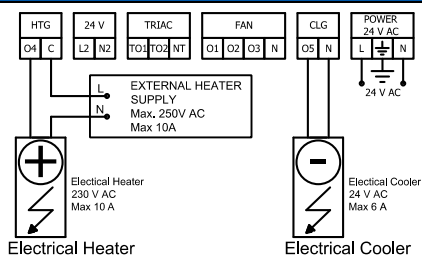

COMMUNICATION

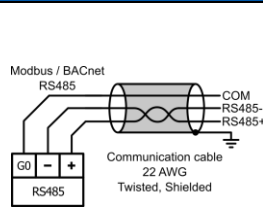

SPECIAL INPUTS

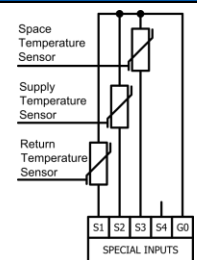

DIGITAL INPUTS

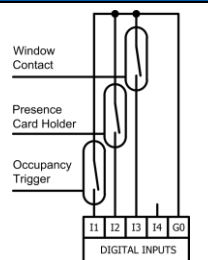

WARNING

- Note, an incorrect wiring of this product can damage it and lead to other hazards. Make sure the product has been correctly wired before turning the power ON.
- Before wiring, or removing/mounting the product, be sure to turn the power OFF. Failure to do so might cause electric shock.
- Do not touch electrically charged parts such as the power terminals. Doing so might cause electric shock.
- Do not disassemble the product. Doing so might cause electric shock or faulty operation.
- Use the product within the operating ranges recommended in the specification (temperature, humidity, voltage, shock, mounting direction, atmosphere etc.). Failure to do so might cause fire or faulty operation.
- Firmly tighten the wires to the terminal. Insufficient tightening of the wires to the terminal might cause fire.

DIMENSION / TOP PANEL

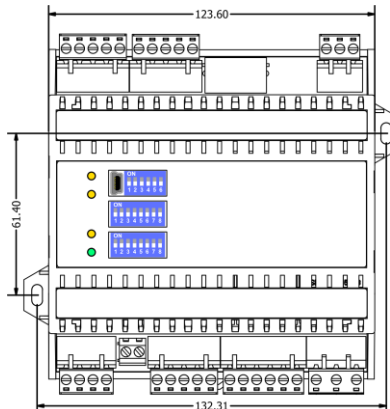

BAUDRATE	PROTOCOL	BIT
1,2,3	4,5	6
000 USER	00 MODBUS RTU	ON = Factory default
010 4800	01 MODBUS ASCII	
011 9600	10 BACnet	
100 19200	11 BACnet SLAVE	
101 38400		
110 57600		
001 76800		
111 115200		



Please read the instruction before use or operating the device. In case of any questions after reading this document, please contact the iSMA CONTROLLI Support Team (support@ismacontrolli.com).



- Before wiring or removing/mounting the product, make sure to turn the power off. Failure to do so might cause an electric shock.
- Improper wiring of the product can damage it and lead to other hazards. Make sure that the product has been correctly wired before turning the power on.
- Do not touch electrically charged parts such as power terminals. Doing so might cause an electric shock.

• Do not disassemble the product. Doing so might cause an electric shock or faulty operation.



- Use the product only within the operating ranges recommended in the specification (temperature, humidity, voltage, shock, mounting direction, atmosphere, etc.). Failure to do so might cause a fire or faulty operation.

- Firmly tighten the wires to the terminal. Failure to do so might cause a fire.

- Avoid installing the product in close proximity to high-power electrical devices and cables, inductive loads, and switching devices. Proximity of such objects may cause an uncontrolled interference, resulting in an instable operation of the product.
- Proper arrangement of the power and signal cabling affects the operation of the entire control system. Avoid laying the power and signal wiring in parallel cable trays. It can cause interferences in monitored and control signals.
- It is recommended to power controllers/modules with AC/DC power suppliers. They provide better and more stable insulation for devices compared to AC/AC transformer systems, which transmit disturbances and transient phenomena like surges and bursts to devices. They also isolate products from inductive phenomena from other transformers and loads.
- Power supply systems for the product should be protected by external devices limiting overvoltage and effects of lightning discharges.
- Avoid powering the product and its controlled/monitored devices, especially high power and inductive loads, from a single power source. Powering devices from a single power source causes a risk of introducing disturbances from the loads to the control devices.
- If an AC/AC transformer is used to supply control devices, it is strongly recommended to use a maximum 100 VA Class 2 transformer to avoid unwanted inductive effects, which are dangerous for devices.
- Long monitoring and control lines may cause loops in connection with the shared power supply, causing disturbances in the operation of devices, including external communication. It is recommended to use galvanic separators.
- To protect signal and communication lines against external electromagnetic interferences, use properly grounded shielded cables and ferrite beads.
- Switching the digital output relays of large (exceeding specification) inductive loads can cause interference pulses to the electronics installed inside the product. Therefore, it is recommended to use external relays/contactors, etc. to switch such loads. The use of controllers with triac outputs also limits similar overvoltage phenomena.
- Many cases of disturbances and overvoltage in control systems are generated by switched, inductive loads supplied by alternating mains voltage (AC 120/230 V). If they do not have appropriate built-in noise reduction circuits, it is recommended to use external circuits such as snubbers, varistors, or protection diodes to limit these effects.



Electrical installation of this product must be done in accordance with national wiring codes and conform to local regulations.